

Overview

SITRANS WS300 is a low- to high-resolution shaft-driven speed sensor.

Benefits

- Compact and economical
- Easy, low-cost installation
- Accurate belt speed detection
- Optional resolutions for measurement over a range of belt speeds
- Corrosion resistant

Application

SITRANS WS300 speed sensor operates in conjunction with a conveyor belt scale, providing a signal to an integrator which computes the rate of material being conveyed. At only 1.22 kg (2.68 lb), it is one of the lightest and most durable units ever developed for monitoring conveyor belt speed. With its rugged cast aluminum housing, it is suitable for outdoor installation, and its low weight prolongs bearing life.

It is directly coupled to a rotating tail or bend pulley shaft to ensure accurate belt-travel readout, eliminating problems caused by belt slippage or material build-up. The WS300 converts shaft rotation into a pulse train of 32, 256, 1 000, or 2 000 pulses per revolution using a high precision rotary optical encoder. The digital signal is transmitted as speed input to any Siemens integrator for calculation of belt speed, flow rate and totalized weight.

This low- to high-resolution speed sensor provides a frequency signal proportional to the shaft speed, enabling a range of speeds to be read accurately. The quadrature type shaft encoder prevents erroneous speed signals due to vibration or shaft oscillation. The WS300 is easily mounted and is bi-directional for either clockwise or counter-clockwise belt travel.

The IS version uses an inductive proximity switch detecting rotating targets.

Belt Weighing

Speed sensors

SITRANS WS300

Design

Mounting

Mounting to a Tail Pulley

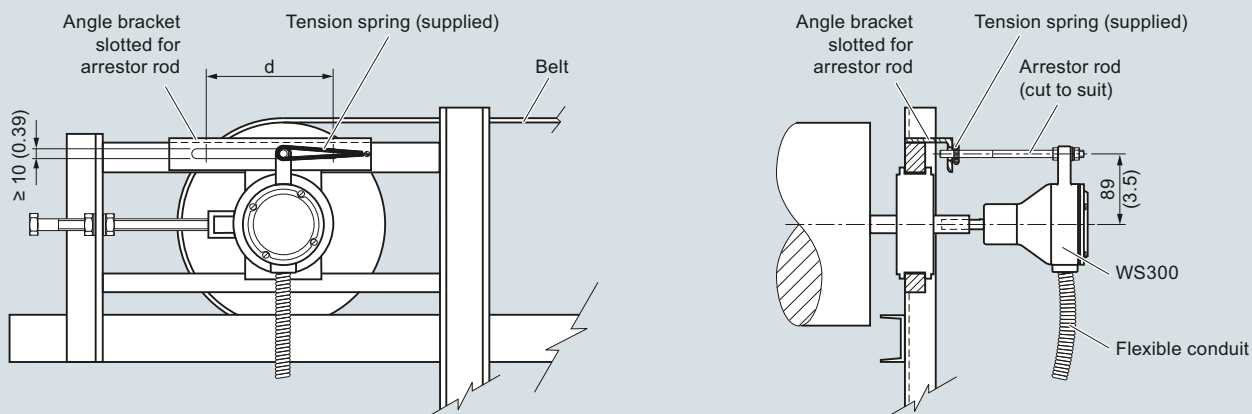

Notes:

Distance 'd' is the take-up travel on the tail pulley.
When adjusting the belt take-up, ensure that there is play on the arrestor rod. If the arrestor rod is pushed against the end of its travel slot, premature bearing wear may result.

Mounting to a Bend or Snub Pulley

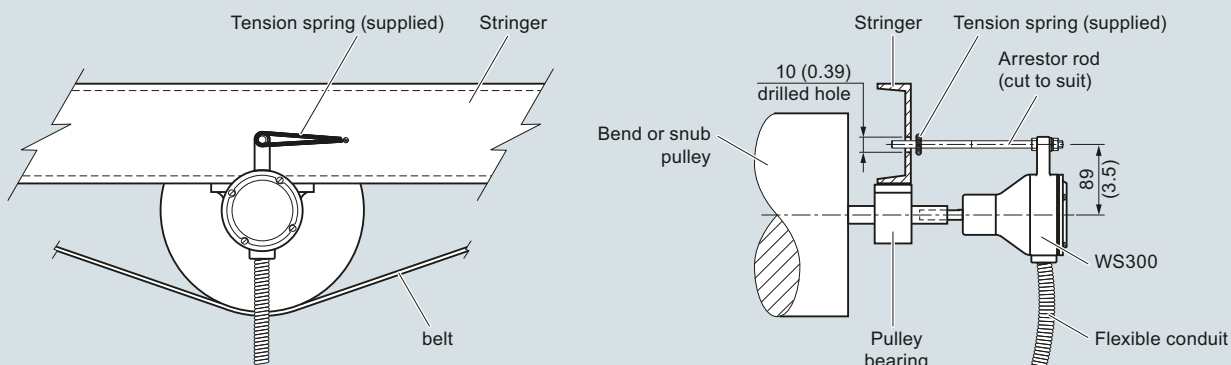

Notes:

When mounting to a bend or a snub pulley only, a 10 mm (0.39 inch) drilled hole is required for the arrestor rod.

WS300 mounting

Mounting using optional threaded shaft coupling

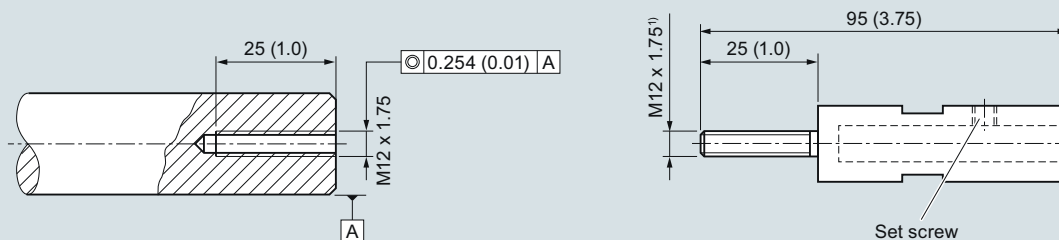

¹⁾ Use adhesive when installing threaded shaft coupling (e.g. Loctite).

WS300 mounting using threaded shaft coupling

Technical specifications

SITRANS WS300		SITRANS WS300	
Measuring principle	Standard: pulse from shaft rotation using high precision rotary optical encoder IS: pulse from inductive proximity switch	Approvals	
Typical application	When a low- to high-resolution speed sensor is required	WS300 Standard	<ul style="list-style-type: none"> • General • CE, RCM, EAC, KCC
Input	Shaft rotation 0.3 ... 2 000 rpm, bi-directional, resolution dependent	Hazardous	<ul style="list-style-type: none"> • CSA/FM Class II, Div. 1, Groups E, F, G; Class III • ATEX I M1, ATEX II 2D Ex tD A21 IP65 T170 °C • MSHA • EAC Ex, RTN • IEC Ex, Ex tD A21 IP65 T70 °C
Output	<ul style="list-style-type: none"> • Unidirectional open collector, NPN, sinking output • Standard: 10 ... 30 V DC, 25 mA max. • IS: NAMUR NC, load current, 0 ... 15 mA • 32, 256, 1 000, or 2 000 pulses per revolution (ppr) • 32 ppr: 2 000 max. rpm, 1 066 Hz • 256 ppr: 2 000 max. rpm, 8 530 Hz • 1 000 ppr: 900 max. rpm, 15 000 Hz • 2 000 ppr: 450 max. rpm, 15 000 Hz 	WS300 IS (with suitable IS switch isolator or switch amplifier) ¹⁾	<ul style="list-style-type: none"> • ATEX II 1G EEx ia IIC T6 • ATEX II 1D Ex iaD 20 T 108 °C • CSA/UL: Class I, Div. 1, Groups A, B, C, and D; Class II, Div. 1, Groups E, F, and G; Class III, Div. 1 • CE, RCM²⁾
Rated operating conditions		Proximity switch approval ratings (Pepperl+Fuchs #NJ0.8-5GM-N)	<ul style="list-style-type: none"> • ATEX II 1G EEx ia IIC T6 • ATEX II 1D Ex iaD 20 T 108 °C • CSA, UL • CE²⁾
Ambient temperature	Standard: -40 ... +70 °C (-40 ... +158 °F) IS: -25 ... +55 °C (-13 ... +212 °F)	Optional switch isolator (required for WS300 IS) ³⁾	<ul style="list-style-type: none"> • Pepperl+Fuchs #KFA5-SOT2-Ex2 or #KFA6-SOT2-Ex2 • ATEX II (1) G [EEx ia] IIC • CSA/UL: Class 1, Div. 1, Groups A, B, C, and D; Class II, Div. 1, Groups E, F, and G; Class III • CE²⁾
Degree of protection	NEMA 4X, Type 4X, IP65		
Design			
Enclosure	<ul style="list-style-type: none"> • Rated NEMA 4X, Type 4X, IP65 • Painted aluminum • Stainless steel (optional) 		
Power supply			
	<ul style="list-style-type: none"> • Standard: 10 ... 30 V DC, 60 mA max. • IS: 5 ... 16 V DC, 25 mA max. (from IS switch isolator) 		
Cable			
Recommended	<ul style="list-style-type: none"> • Standard: 3-wire shielded, 0.82 mm² (18 AWG) • IS: 2-wire shielded 0.324 mm² (22 AWG) • Max. run 305 m (1 000 ft) 		

¹⁾ Approvals for WS300 IS are based on internally mounted NAMUR proximity switch (Pepperl+Fuchs #NJ0.8-5GM-N) and use of suitable IS switch isolator (amplifier). Please see WS300 operating instructions for more information.

²⁾ Approvals for WS300 IS are based on internally mounted NAMUR slotted proximity switch (Pepperl+Fuchs #NJ0.8-5GM-N) and use of suitable IS switch isolator (amplifier). Please see WS300 operating instructions for more information.

³⁾ Approval ratings for the proximity switch and IS switch isolator are the property of Pepperl+Fuchs. Copies of these approval certificates may be obtained at <http://www.siemens.com/processautomation>.

Belt Weighing

Speed sensors

SITRANS WS300

Selection and ordering data

SITRANS WS300 speed sensor

A medium- to high-resolution shaft-driven speed sensor used with Milltronics belt scales.

➤ Click on the Article No. for the online configuration in the PIA Life Cycle Portal.

Resolution (pulses per revolution)

32
256
1 000
2 000

Article No.

7MH7177-

0

1
2
3
4

Enclosure

C5-M rated polyester painted aluminum, NEMA 4X
304 (1.4301) stainless steel, vibra finish NEMA 4X

A
B

Approvals

CSA/FM Class II, Div. 1, Groups E, F, G Class III
ATEX II 2D, Ex tD A21 IP65 T70 °C, EAC Ex
CE, RCM, IEC Ex, Ex tD A21 IP65 T70 °C

A

CSA/UL Class I, Div. 1, Groups A, B, C, and D;
Class II, Div. 1, Groups E, F, and G;
Class III, Div. 1, ATEX II 1G, EEx ia IIC T6, ATEX II
1D Ex iaD 20 T108 °C, CE, RCM¹⁾²⁾

B

CE, RCM, EAC, KCC

D

ATEX I, II M1, 1GD, Ex ia I Ma, Ex ia IIC T4 Ga, Ex ia
IIIC T135 °C Da, Ex h I Ma, Ex h IIC T4 Ga, Ex h IIIC
T135 °C Da ATEX I M1, IEC Ex M1, MSHA 4²⁾

E

Connections

Standard, up to 2 integrators
Multiple, up to 10 integrators

1
2

Switch isolator

Not required
115 V AC³⁾
230 V AC³⁾

0
1
2

Further designs

Please add **"-Z"** to article no. and specify order code(s).

Order Code

Acrylic coated, stainless steel tag [13 x 45 mm
(0.5 x 1.75 inch)]: Measuring-point number/identifi-
cation (max. 16 characters), specify in plain text

Y17

Manufacturer's test certificate:
According to EN 10204-2.2

C11

Operating instructions

English

Article No.

7ML1998-5ML01

Note: the operating instructions should be ordered as a separate item on the order.

All literature is available to download for free, in a range of languages, at
<http://www.siemens.com/weighing/documentation>

Spare parts

Circuit card 32 PPR, up to 2 integrators

7MH7723-1GL

Circuit card 32 PPR, up to 10 integrators

7MH7723-1GK

Circuit card 256 PPR, up to 2 integrators

7MH7723-1GM

Circuit card 256 PPR, up to 10 integrators

7MH7723-1GN

Circuit card 1 000 PPR, up to 2 integrators

7MH7723-1GP

Circuit card 1 000 PPR, up to 10 integrators

7MH7723-1GQ

Circuit card 2 000 PPR, up to 2 integrators

7MH7723-1JL

Circuit card 2 000 PPR, up to 10 integrators

7MH7723-1JM

Circuit card 32 PPR, IS

7MH7723-1HC

Rubber coupling

7MH7723-1CM

Coupling hub for 32, 256 PPR versions

7MH7723-1CN

Coupling hub for 1 000, 2 000 PPR versions

7MH7723-1GR

Enclosure cover

7MH7723-1CJ

Enclosure cover, stainless steel

7MH7723-1GS

Enclosure bearing assembly, stainless steel

7MH7723-1GT

Threaded shaft coupling

7MH7723-1GH

Arrestor rod

7MH7723-1FV

Arrester rod tension spring

7MH7723-1CP

WS300 mounting bracket for MD-36 retrofit

7MH7723-1NB

WS300 mounting bracket SS for MD-36 retrofit

7MH7723-1NC

Cable for speed sensor connection to termination
box 3 cond, 18G (order per meter)⁴⁾

7MH7723-1JP

Cable for IS speed sensor connection to termina-
tion box 3 cond, 22G (order per meter)⁴⁾

7MH7723-1JQ

Pepperl+Fuchs IS switch isolator, 115 V AC

7MH7723-1EB

Pepperl+Fuchs IS switch isolator, 230 V AC

7MH7723-1EC

¹⁾ The Approval Ratings for the Proximity Switch and the IS switch isolator are the property of Pepperl+Fuchs. For current approvals, go to: <http://www.am.pepperl-fuchs.com>.

²⁾ Approval options B and E require the use of switch isolator to interface with the belt scale integrator, and are available with Resolution option 1, and Connections option 1 only.

³⁾ For use with IS approval options B and E.

⁴⁾ Cable length orders exceeding 150 m (500 ft) may not be supplied as a continuous length.

Dimensional drawings

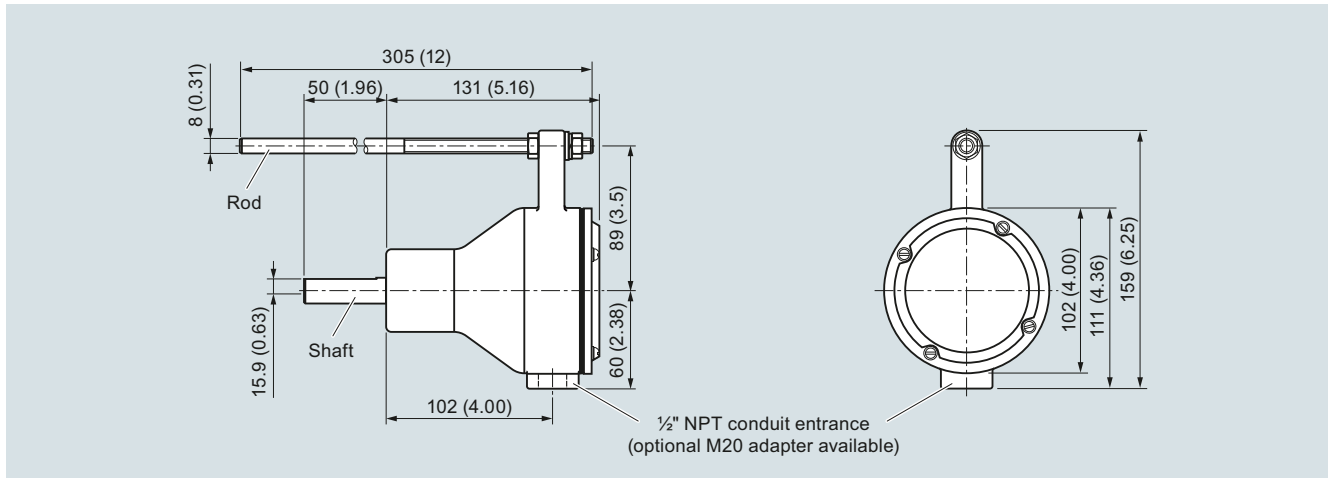

WS300, dimensions in mm (inch)

Circuit diagrams

Connections (Standard)

Description	Terminal
10 ... 30 V DC	1
Speed out-CW	2
Speed out-CCW	3
Common	4
Ground	GND

- Determine the pulley shaft rotation on the end of the pulley shaft to which the WS300 is attached.
- If the pulley shaft is rotating clockwise, connect the appropriate wire to terminal 2. If the pulley shaft is rotating counter-clockwise, connect the appropriate wire to terminal 3.
- Do not connect terminals 2 and 3 at the same time.
- Connection between the WS300 standard unit and the integrator should be made with three-wire shielded, 0.82 mm² (18 AWG) cable.
- Ground shield of cable at integrator only.
- Connect shield to appropriate terminal at the integrator.

Terminal Connections to integrator

WS300	1 +V	2 CW	3 CCW	4 Cmn	GND
Milltronics BW500	19	16	16	17	N/C
SIWAREX FTC	CI+, 1L+	CI-	CI-	1M	N/C
SIWAREX WP241	1L+	DI.0	DI.0	2M, 1M	N/C

Connections (IS)

Description	Terminal
5 ... 16 V DC, 25 mA max. (from IS Switch Isolator)	1
Speed out	2
Ground	GND

- Only terminals 1 and 2 are required; rotation in a clockwise or counter-clockwise direction is not required.
- To connect the switch isolator, use two-wire shielded 0.324 mm² (22 AWG) cable. Use the same cable to connect the switch isolator to the integrator.
- Ground shield of cable at integrator only.
- Connect shield to appropriate terminal at the integrator.

Terminal Connections to integrator

W300 IS	IS Switch Isolator Terminal	Milltronics BW500	SIWAREX FTC	SIWAREX WP241
1	3			
2	1			
	7	16	1L+	1L+
	8	17	CI+	CI+

Connect CI- to Common